

A flexible simple setup that works with any rifle or shotgun

- Gun lock + butt plate for either a rifle or a shotgun or
- Gun lock + muzzle cup for rifle or
- Gun lock + muzzle plug for shotgun

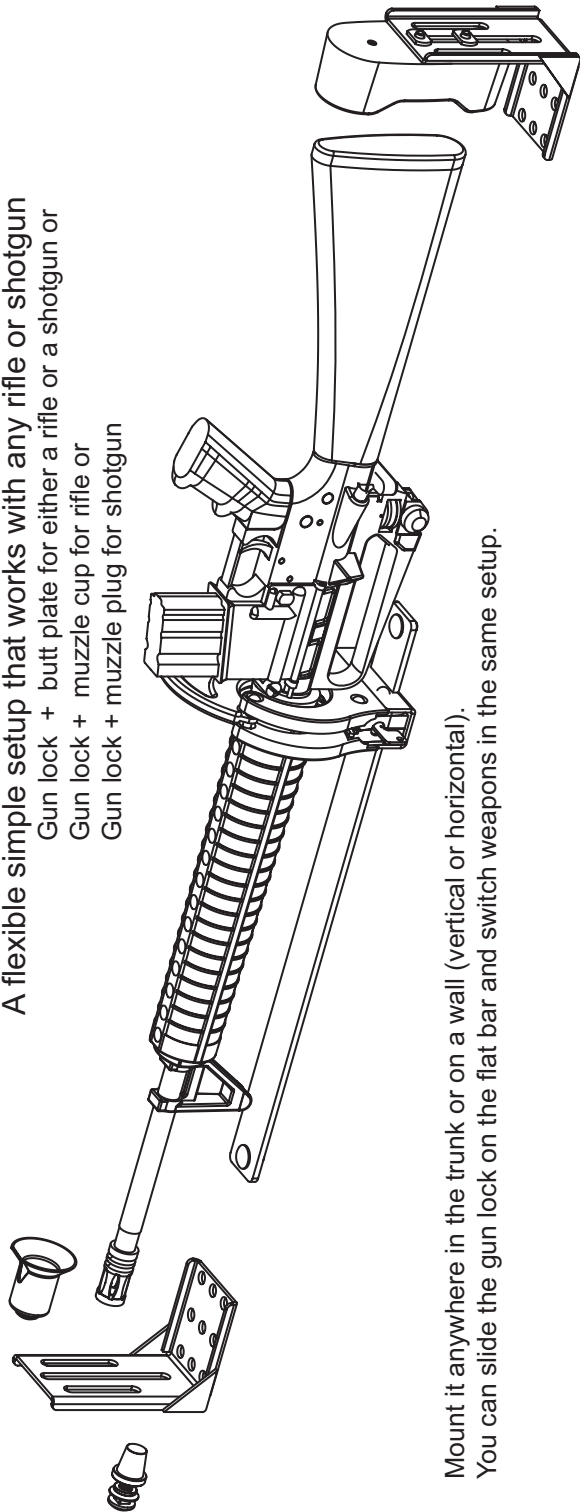

Mount it anywhere in the trunk or on a wall (vertical or horizontal).
You can slide the gun lock on the flat bar and switch weapons in the same setup.

Manual Key Override feature
The gunlock has a manual - key operated - override feature to open the lock in case of electrical failure.
You do not have to use the key but it is there, ready to open the gunlock, should you ever need it. Just insert the key provided with the lock (exception: handcuff keys are not shipped) and, depending on your key type, turn it 90 or 180 degrees counter clockwise to open the lock and remove your weapon.
Note: the two ways to open the lock - electric and manual key operated - work independently.

Package contents

- 1 x Model SC-5 Universal Gunlock
- 2 x 5/16-18 x 3/4" mounting screws
- 2 x 5/16" lock washers
- 1 x push-button switch
- 1 x this installation instructions

We reserve the right to change design and price without notice any time.

LIMITED WARRANTY
Santa Cruz Gunlocks, LLC. (SCG) warrants this product to be free of defects in material and workmanship under normal use for the life of the car it was originally installed in new. SCG makes no other express or implied warranties of the product. The purchaser's sole and exclusive remedy in the unlikely event of breach of warranty is expressly limited to, at SCG's election, repair, refurbishment, or replacement of the defective product with the same version or an upgrade or, if replacement is not possible, a refund of the purchase price.
Shipping cost to SCG must be paid by the user and SCG will pay return shipping charges. Repair parts and replacement products will be provided on an exchange base only and will be either reconditioned or new. This limited warranty does not cover damage to the product resulting from accident, disaster, misuse, abuse, negligence, improper installation or modification or repair of the product other than by SCG. Limited warranty service may be obtained by returning the product to SCG at the address below.
THIS LIMITED WARRANTY IS IN LIEU OF ALL OTHER WARRANTIES, EXPRESS OR IMPLIED, INCLUDING, BUT NOT LIMITED TO, THE IMPLIED WARRANTIES OF MERCHANTABILITY AND FITNESS FOR A PARTICULAR PURPOSE. Some states, do not allow the exclusion of implied warranties, so their exclusion above may not apply to you.
LIMITATION OF LIABILITY
NEITHER SCG NOR ITS AUTHORIZED DEALER(S) SHALL BE LIABLE FOR ANY DIRECT, INDIRECT, INCIDENTAL, SPECIAL, OR CONSEQUENTIAL DAMAGES, WHETHER IN AN ACTION IN CONTRACT OR TORT (INCLUDING NEGLIGENCE AND STRICT LIABILITY), SUCH AS, BUT NOT LIMITED TO, LOSS OF ANTICIPATED PROFITS OR BENEFITS RESULTING FROM THE USE OR NOT USE OF THE PRODUCT OR ANY BREACH OF ANY WARRANTY, EVEN IF SCG OR ITS AUTHORIZED REPRESENTATIVE HAS BEEN ADVISED OF THE POSSIBILITY OF SUCH DAMAGES. IN NO EVENT WILL SCG OR ITS AUTHORIZED REPRESENTATIVES' LIABILITY EXCEED THE PRICE PAID FOR THE PRODUCT.

SANTA CRUZ GUNLOCKS, LLC.
450 Tyler Rd.
Webster, NH 03303
Phone: (603)746-7740 Fax: (603)746-7764
1-800-847-5428
E-mail: info@santacruzgunlocks.com
www.SantaCruzGunlocks.com



**Model SC-5
Universal Gunlock**

Patent Pending

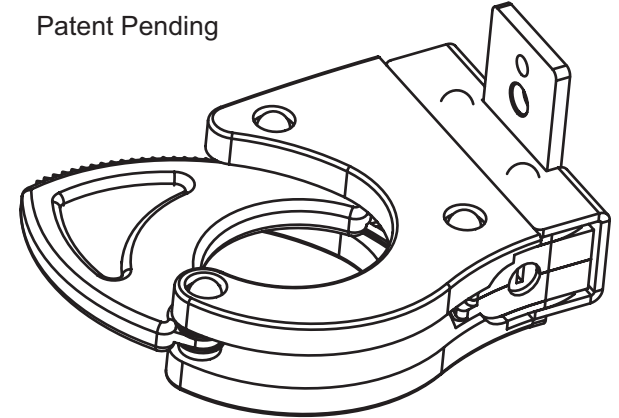

Installation Step 1.

Decide your mounting options.
A wide variety of mounting brackets are available from Santa Cruz and other suppliers. However, to mount the gunlock anywhere, all you need is either:

Option 1.

A min. 1.5" x 4.0" solid flat surface and two 5/16" - 3/8" diameter holes spaced 2.50" apart.

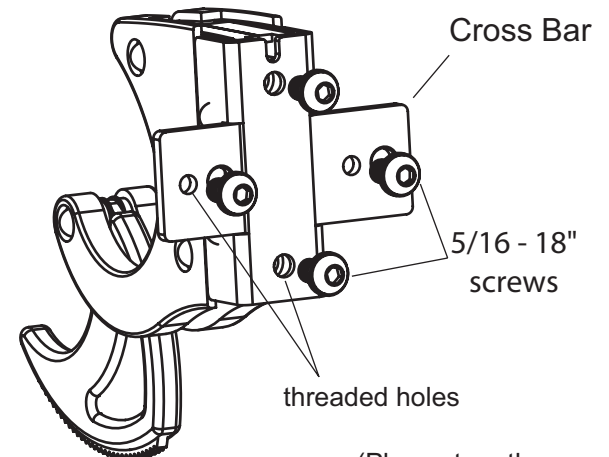

(Please turn the page)

Option 2.

Cut a commercially available standard 1.50" wide and 3/16" thick steel bar to desired length. Drill holes at suitable mounting locations. Slide this bar through the rectangular opening in the bottom of the gunlock and secure lock position with the internal set screw using a 5/32" or 4.0 mm hex key through the opening provided in the lock body.

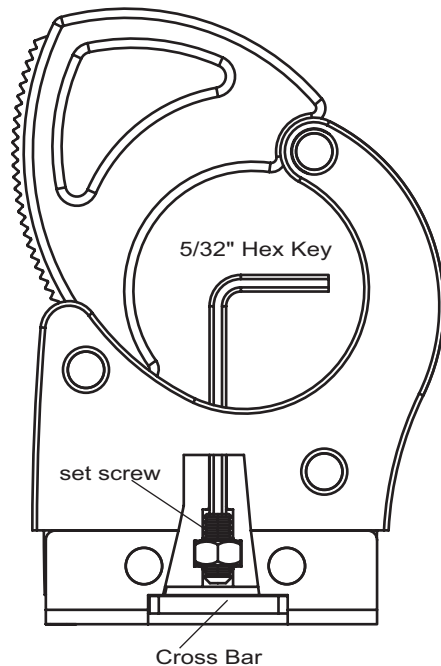

Step 2.

Use the two 5/16-18" screws supplied to mount the gunlock to the bracket and install the bracket following bracket manufacturer's instructions.

Find a concealed yet accessible location for the push-button switch supplied with the gunlock or use one of the switches available on your vehicle's center console.

There are two wires coming out from the back of the gunlock. They are the two ends of the solenoid coil. It does not matter which one you use for positive or negative. Connect one of the wires to a good solid ground. It is very important to have a good ground connection.

Use a separate wire (not supplied) to connect the other solenoid lead to one terminal of the push-button switch.

Connect another wire (not supplied) from the other terminal of the push-button switch to the ignition terminal that is HOT only with the ignition turned ON.

Use a quick acting (5 Amp) fuse (not supplied) between the ignition switch terminal and the lead coming from the push-button switch.

To secure your weapon:

Place the weapon in the open cradle of the lock and fold the ratchet arm over the gun.

Press down SLIGHTLY on the arm after the rubber cushion of the ratchet arm contacts the gun. The ratchet mechanism should only click one more from weapon contact and NO MORE.

THERE IS NO NEED TO PRESS THE ARM DOWN HARD. YOU DO NOT NEED MORE THAN 1 CLICK. Keep it nice and light. Your weapon is already secure and will not go anywhere.

To remove your weapon:

Press the push-button release switch and simply fold back the ratchet arm and remove your weapon.

If you have a delay timer installed, you can release the button and the timer will keep the circuit activated for the specified time period (cca. 10 sec);

If you do not have a timer, you will have to keep the push-button activated with one hand and use your other hand to remove the weapon.

You will have to press or tap (bump) on the outer rubber surface of the ratchet arm if you pushed down too strong the ratchet arm at the time you installed your weapon in the lock. This will release the backup safety inside the lock and releases the weapon.

Installation tips

With the Model SC-5 universal gunlock you are not limited to the conventional weapon holding locations. You can grab the weapon practically anywhere from the handgrip behind the trigger guard to the tip of the barrel.

However:

You should install the gunlock in a way that would prevent unauthorized operation of the weapon by blocking moving/operating components.

You should secure a weapon at least two locations on the gun. These two locations should be as far from each other as possible to have the most secure installation.

One such safe mounting example is using a Butt Plate (Part no. SC-1900) holding the buttstock of the rifle and installing the Model SC-5 universal gunlock somewhere along the weapon where it would both

- block the action and

- prevent anyone from lifting the gun out of the Butt Plate.

Always check the other side of the surface for electrical or other components and wires when drilling anywhere.

Always use the actual weapon when making measurements.

MAINTENANCE

Once a month, use any heavy grease to lightly lubricate the lockpin and the teeth of the ratchet arm. Use oil to lubricate ratchet arm pivot point. Adverse conditions (ocean service) require more frequent lubrication.