

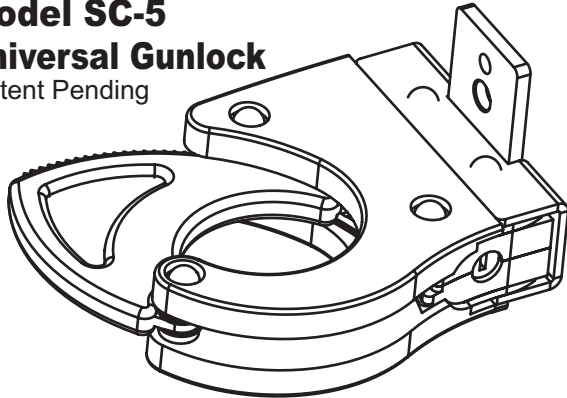

Model SC-5
Universal Gunlock
Patent Pending



STOP! STOP! STOP!
READ YOUR LIMITED WARRANTY FIRST

Santa Cruz Gunlocks, LLC. (SCG) warrants this product to be free of defects in material and workmanship under normal use for one year from the date of purchase. SCG makes no other express or implied warranties. Installation of the product is totally outside the control of SCG, consequently we are specifically declining any warranty related to installation. The purchaser's sole and exclusive remedy in the unlikely event of breach of warranty is expressly limited to, at SCG's election, repair, refurbishment, or replacement of the defective product with the same version or an upgrade or, if replacement is not possible, a refund of the purchase price. Shipping cost to SCG must be paid by the user and SCG will pay return shipping charges. Repair parts and replacement products will be provided on an exchange base only and will be either reconditioned or new. This limited warranty does not cover damage resulting from accident, disaster, misuse, abuse, negligence, installation or modification or repair of the product other than by SCG. Limited warranty service may be obtained by returning the product to SCG. THIS LIMITED WARRANTY IS IN LIEU OF ALL OTHER WARRANTIES, EXPRESS OR IMPLIED, INCLUDING, BUT NOT LIMITED TO, THE IMPLIED WARRANTIES OF MERCHANTABILITY AND FITNESS FOR A PARTICULAR PURPOSE. Some states do not allow the exclusion of implied warranties, so their exclusion above may not apply to you. LIMITATION OF LIABILITY. NEITHER SCG NOR ITS AUTHORIZED DEALER(S) SHALL BE LIABLE FOR ANY DIRECT, INDIRECT, INCIDENTAL, SPECIAL OR CONSEQUENTIAL DAMAGES, WHETHER IN AN ACTION IN CONTRACT OR TORT (INCLUDING NEGLIGENCE AND STRICT LIABILITY), SUCH AS, BUT NOT LIMITED TO, LOSS OF ANTICIPATED PROFITS OR BENEFITS RESULTING FROM THE USE OR NOT USE OF THE PRODUCT OR ANY BREACH OF ANY WARRANTY, EVEN IF SCG OR ITS AUTHORIZED REPRESENTATIVE HAS BEEN ADVISED OF THE POSSIBILITY OF SUCH DAMAGES. IN NO EVENT WILL SCG OR ITS AUTHORIZED REPRESENTATIVES' LIABILITY EXCEED THE PRICE PAID FOR THE PRODUCT.

If you do not agree to the above warranty, stop and do not install the product. Return to the place of purchase and your purchase price will be refunded. Damaged or used products can not be returned for a full refund.

Installation

Select the weapon(s) you want to secure and decide your mounting position. See enclosed mounting samples for a Colt AR-15 semi-auto rifle and a Remington 870 pump shotgun.

Your mounting options are almost unlimited, but there are some general rules:

- o The strength and security of your setup is determined by the strength of the surface you mount the FLAT BAR on. You must find something strong like 2" x 4" studs to drill into.
- o You must slide the gun lock on flat bar so an integral part of the weapon is against the gun lock. This will block weapon from lifting/pulling out of the butt plate.
- o You are safest to install your setup in an otherwise restricted area (wardrobe corner, cabinet) where other furniture/wall elements limit the force that can be applied to rip the whole setup out from the wall.

Step 1.

Locate the centerline of 2" x 4" studs at your intended mounting location behind the wall.

Step 2.

Slide flat bar into the rectangular space at the bottom of the gun lock. Use the 5/32" Allen key provided to stop flat bar movement by slightly tightening the internal set screw. Mount both gun lock and butt plate on your weapon and position the whole assembly at your intended location. Butt plate should be on the floor and the two holes on the flat bar should line up with the center line of a strong stud behind the wall. Align the assembly.

Step 3.

Mark the mounting hole locations in both flat bar and butt plate.

Step 4.

Check weapon and setup alignment again before drilling any holes. It is good to have an assistant to help you hold components in place.

Step 5.

Pre-drill for one-way screws with a 7/32" drill bit. Pre-drill for sheetmetal screws with a 3/16" drill bit. Install one-way security screws through the flat bar and large washers. Install sheetmetal screws through the butt plate. Tighten screws and check your setup.

Step 5.

Readjust gun lock position. Release internal set screw with 5/32" allen key. Slide gun lock down on flat bar to seat against the weapon feature that will prevent lifting the weapon out of the butt plate. Retighten set screw and check your installation by inserting/removing the weapon several times.

IMPORTANT! IMPORTANT!
DO NOT TIGHTEN RATCHET ARM TO MORE THAN ONE CLICK AFTER THE ARM CONTACTS THE WEAPON. YOUR WEAPON IS ALREADY SECURE.

MAINTENANCE

Once a month, use any heavy grease to lightly lubricate the lockpin and the teeth of the ratchet arm. Use oil to lubricate ratchet arm pivot point. Adverse conditions (ocean service) require more frequent lubrication.

IMPORTANT

Should you have any problem installing or using Santa Cruz products, we are here to help you every step of the way.

Just give us a call at our toll free number (800) 847-5428 and we will be glad to help you with the installation, special part request or any other way you might need assistance.

SANTA CRUZ GUNLOCKS, LLC.
450 Tyler Rd. Webster, NH 03303
Phone: (603)746-7740 Fax: (603)746-7764
E-mail: info@santacruzgunlocks.com
www.SantaCruzGunlocks.com

PARTS SHIPPED

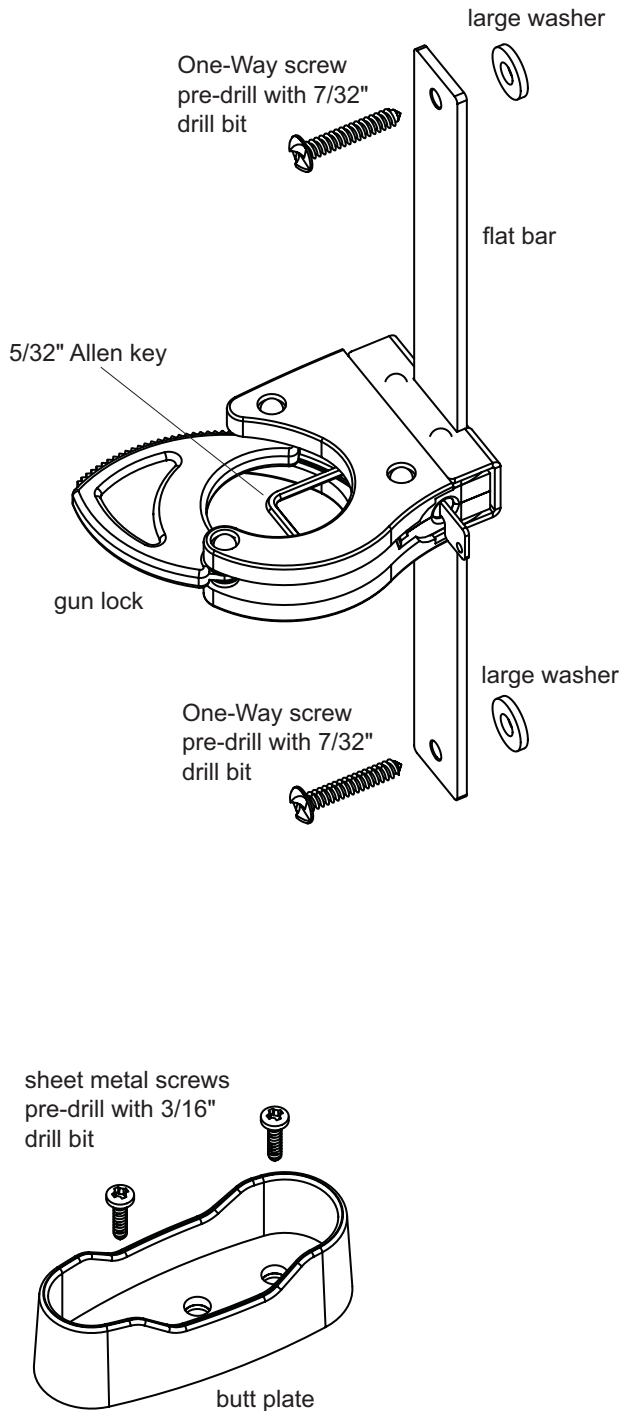

Colt AR-15 Vertical Samples

Notice gun lock location on weapon.
Magazine well blocks lifting gun.

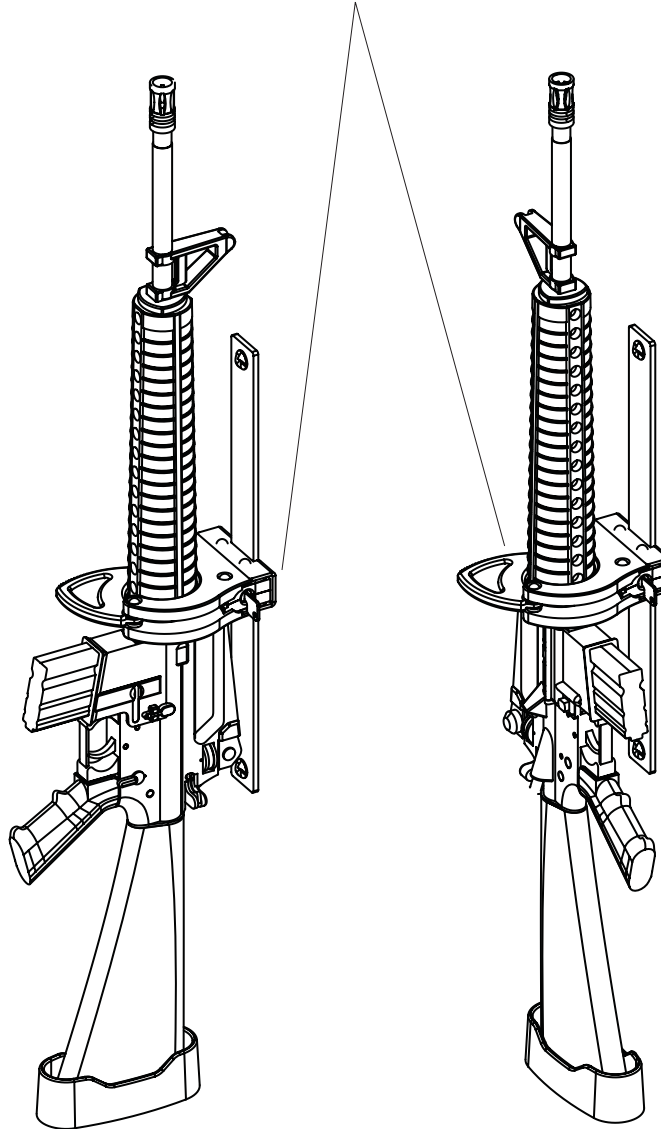

Remington 870 Vertical Samples

Notice gun lock location on weapon.
End of magazine blocks lifting gun.

