

INSTALLATION

1. Install SC-1900 Butt Plate on SC-9151 butt plate support bracket. Do not tighten screws just yet.
2. Place weapon in butt plate and position the assembly at the bottom of the cage so the bracket is in the center of the drive shaft housing. Determine the correct angle of the bracket and mark mounting hole points in the lower panel of the cage. Drill two holes and install SC-9151 bracket using the supplied 5/16-18" carriage bolts.
3. Position SC-502 Flat Bar directly in line over the butt plate assembly and mark mounting holes in flat bar over to the cage. Drill holes.
4. Slide flat bar into the rectangular hole in the bottom of SC-5 gun lock. Using the supplied thick washers under flat bar mounting holes, bolt flat bar and gun lock assembly to the partition wall with 2 x 5/16-18" carriage bolts.
5. Install weapon in Butt Plate and slide gun lock on flat bar to a suitable location on the weapon so when lock is closed you can not lift weapon out of the butt plate. Secure gun lock on flat bar using the supplied 5/32" allen key.
6. Insert and remove weapon from the setup several times to make sure the weapon is secure and also easy to take it out of the setup. Tighten all screws.

We reserve the right to change design and prices without notice.

IMPORTANT

Should you have any problem installing or using Santa Cruz products, we are here to help you every step of the way.

Just give us a call at our toll free number (800) 847-5428 and we will be glad to help you with the installation, special part request or any other way you might need assistance.

OTHER PRODUCTS AVAILABLE FROM SANTA CRUZ

Gunlocks:

- o Model SC-1 for pump shotguns
- o Model SC-1/AR for automatic shotguns
- o Model SC-5 Universal for any weapon

Mounting Brackets:

- o Model SC-915/P Partition wall
- o Model SC-931 Muzzle Down
- o Model SC-917 Wall/Trunk
- o Model SC-934 Overhead

Accessories:

- o Solenoid (SC-1909)
- o Spare keys (specify style or number)
- o Butt Plate (SC-1900) adjustable
- o Butt Plate (SC-1901) solid
- o Timer (SC-7009)
- o Mounting hinge (SC-9302)

LIMITED WARRANTY
Santa Cruz Gunlocks, LLC. (SCG) warrants this product to be free of defects in material and workmanship under normal use for the life of the car it was originally installed in new. SCG makes no other express or implied warranties of the product. The purchaser's sole and exclusive remedy in the unlikely event of breach of warranty is expressly limited to, at SCG's election, repair, refurbishment, or replacement of the defective product with the same version or an upgrade or, if replacement is not possible, a refund of the purchase price. Shipping cost to SCG must be paid by the user and SCG will pay return shipping charges. Repair parts and replacement products will be provided on an exchange base only and will be either reconditioned or new. This limited warranty does not cover damage to the product resulting from accident, disaster, misuse, abuse, negligence, improper installation or modification or repair of the product other than by SCG. Limited warranty service may be obtained by returning the product to SCG at the address below.
THIS LIMITED WARRANTY IS IN LIEU OF ALL OTHER WARRANTIES, EXPRESS OR IMPLIED, INCLUDING, BUT NOT LIMITED TO, THE IMPLIED WARRANTIES OF MERCHANTABILITY AND FITNESS FOR A PARTICULAR PURPOSE. Some states, do not allow the exclusion of implied warranties, so their exclusion above may not apply to you.

LIMITATION OF LIABILITY
NEITHER SCG NOR ITS AUTHORIZED DEALER(S) SHALL BE LIABLE FOR ANY DIRECT, INDIRECT, INCIDENTAL, SPECIAL, OR CONSEQUENTIAL DAMAGES, WHETHER IN AN ACTION IN CONTRACT OR TORT (INCLUDING NEGLIGENCE AND STRICT LIABILITY), SUCH AS, BUT NOT LIMITED TO, LOSS OF ANTICIPATED PROFITS OR BENEFITS RESULTING FROM THE USE OR NOT USE OF THE PRODUCT OR ANY BREACH OF ANY WARRANTY, EVEN IF SCG OR ITS AUTHORIZED REPRESENTATIVE HAS BEEN ADVISED OF THE POSSIBILITY OF SUCH DAMAGES. IN NO EVENT WILL SCG OR ITS AUTHORIZED REPRESENTATIVES' LIABILITY EXCEED THE PRICE PAID FOR THE PRODUCT.



SC-915-5-A Adjustable Partition Wall Bracket

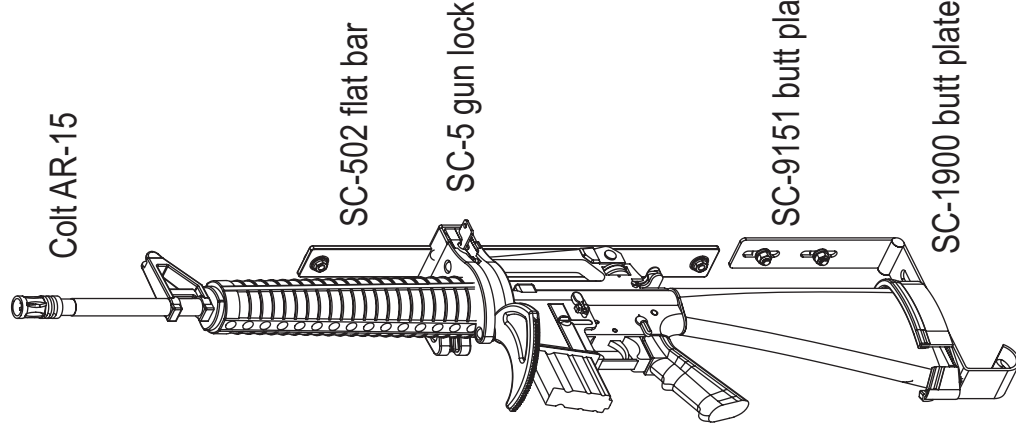

Santa Cruz Wall Brackets are designed to be mounted between bucket seats on a partition wall in vertical muzzle-up position. The version above lets you exchange most any weapons in the same setup.

SANTA CRUZ GUNLOCKS, LLC.

450 Tyler Rd.

Webster, NH 03303

Phone: (603)746-7740 Fax: (603)746-7764

1-800-847-5428

E-mail: info@SantaCruzGunlocks.com

www.SantaCruzGunlocks.com

Model SC-915-5-A Partition Wall Setup

Use or exchange any single weapon
in the same setup

Complete installation kit for shotguns or rifles
Components included:

- o SC-5 gun lock (specify key: #2 or handcuff)
- o SC-1900 or 1901 butt plate
- o SC-9151 butt plate hinge
- o SC-502 18" long flat bar
- o nuts and bolts

- To exchange weapon
- o Release set screw with 5/32 hex key supplied.
 - o Slide gun lock up or down on flat bar.
 - o Retighten set screw in new gun lock position.
 - o Test that weapon can not be lifted from butt plate.

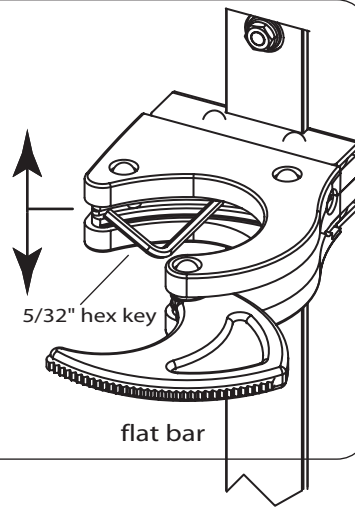

SC-5
gun lock

flat bar

SC-1900
Butt Plate



if your partition wall has a recess
in the center, you do not need
the butt plate hinge (SC-9151).

5/32" hex key

set screw

flat bar

